

JST12-5.0

Characteristics

Nominal Voltage		12V
Nominal Capacity (20 hour rate)		5.0Ah
Capacity 25°C (77°F)	20 hour rate (0.25A)	5.0Ah
	10 hour rate (0.475A)	4.75Ah
	5 hour rate (0.8A)	4.00Ah
	1 hour rate (3.25A)	3.25Ah
Internal Resistance	Full Charged Battery 25°C (77°F)	≤38mΩ
Cyclic Life	50%(C ₂₀) Depth of discharge	600Times
Float Life	25°C (77°F) Float charge at 13.8V	About 3 Years
Capacity affected by Temperature (20 hour)	40°C (104°F)	102%
	25°C (77°F)	100%
	0°C (32°F)	85%
	-15°C (5°F)	65%
Self-Discharge 25°C (77°F)	Capacity after 3 month storage	90%
	Capacity after 6 month storage	80%
	Capacity after 12 month storage	62%
Charge (Constant Voltage) 25°C (77°F)	Cycle	Initial Charging Current Less than 1.5A Voltage 14.6-15.0V
	Float	Voltage 13.5-13.8V

Product Image



Packing

Battery (L×W×H)	mm ± 1	90×70×101
	inch	3.55×2.76×3.98
Box (L×W×H)	mm ± 2	375×195×125
	inch	14.8×7.68×4.93
Quantity Per Box		10 PCS
Net weight Per Cell		1.5Kg±30g
Net weight Per Box		15.0 Kg
Gross Weight		15.3Kg

Discharge Curve

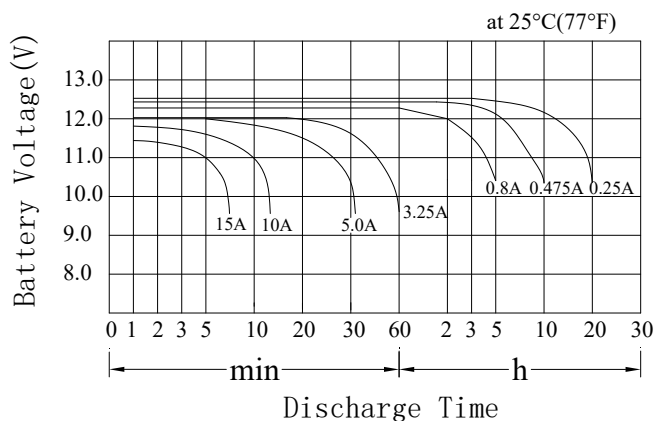

Product Dimensions

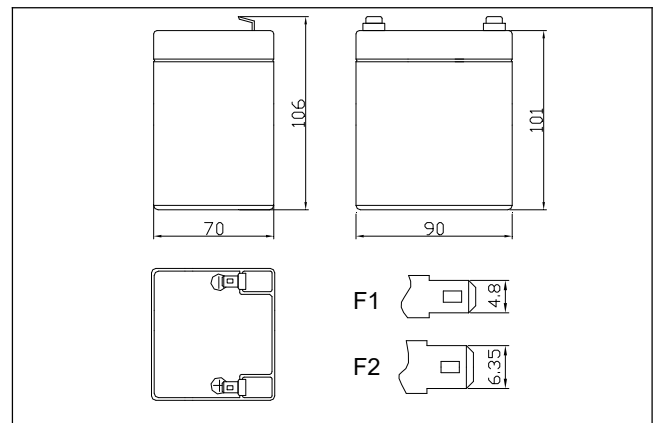

Battery Construction

Component	Positive plate	Negative plate	Container	Safety valve	Terminal	Separator	Electrolyte
Raw Material	Lead dioxide	Lead	ABS	Rubber	Copper	Fiberglass	Sulfuric acid

Discharge Characteristics

Voltage	Run Time (Constant Current and Power 25°C 77° F)											
	3 min	5 min	15 min	30 min	45 min	1h	2h	3h	5h	8h	10h	20h
9.6 V	216	191	111	67.0	46.8	37.5	20.2	14.7	9.95	6.55	5.45	2.97
10.2V	195	175	99.5	61.5	45.6	36.9	19.9	14.5	9.85	6.55	5.45	2.97
10.5V	162	153	94.0	58.0	45.1	36.3	19.6	14.3	9.85	6.45	5.40	2.91
10.8V	151	137	88.5	50.0	44.5	35.7	19.0	13.9	9.75	6.45	5.30	2.85

