

JST12-2.3

Characteristics

Nominal Voltage		12V
Nominal Capacity (20 hour rate)		2.3Ah
Capacity 25°C(77°F)	20 hour rate (0.115A)	2.3Ah
	10 hour rate (0.218A)	2.18Ah
	5 hour rate (0.368A)	1.84Ah
	1 hour rate (1.49A)	1.49Ah
Internal Resistance	Full Charged Battery 25°C(77°F)	≤50mΩ
Cyclic Life	50%(C ₂₀) Depth of discharge	600Times
Float Life	25°C(77°F) Float charge at 13.8V	About 5 Years
Capacity affected by Temperature (20 hour)	40°C (104°F)	102%
	25°C (77°F)	100%
	0°C (32°F)	85%
	-15°C (5°F)	65%
Self-Discharge 25°C(77°F)	Capacity after 3 month storage	90%
	Capacity after 6 month storage	80%
	Capacity after 12 month storage	62%
Charge (Constant Voltage) 25°C (77°F)	Cycle	Initial Charging Current Less than 0.69A Voltage 14.6-15.0V
	Float	Voltage 13.5-13.8V

Product Image



Packing

Battery (L×W×H)	mm ± 1	178×34×65
	inch	7.01×1.34×2.56
Box (L×W×H)	mm ± 2	375×313×86
	inch	15.8×14.6×3.66
Quantity Per Box		16 PCS
Net weight Per Cell		0.90Kg ± 15g
Net weight Per Box		14.8Kg
Gross Weight		15.2 Kg

Discharge Curve

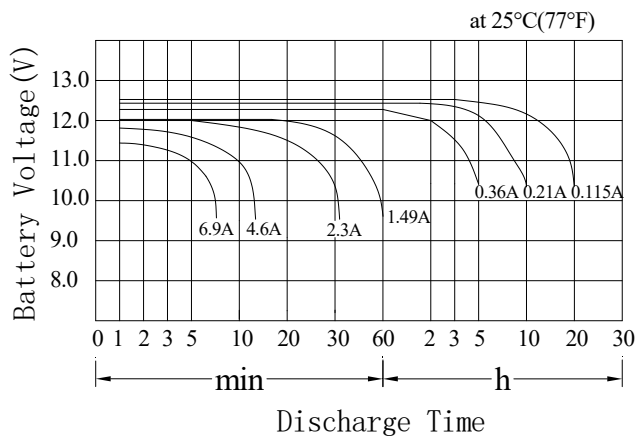

Product Dimensions

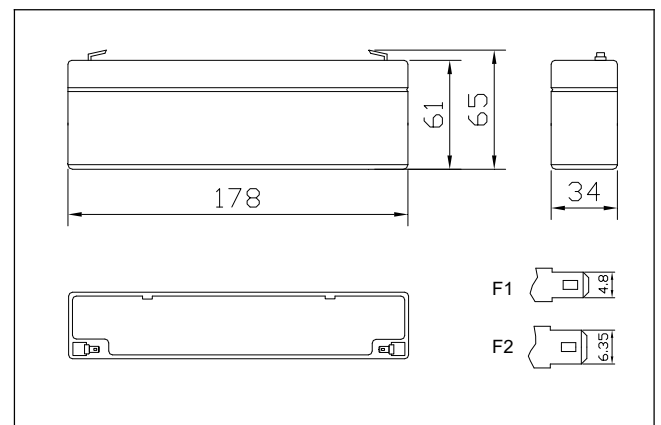

Battery Construction

Component	Positive plate	Negative plate	Container	Safety valve	Terminal	Separator	Electrolyte
Raw Material	Lead dioxide	Lead	ABS	Rubber	Copper	Fiberglass	Sulfuric acid

Discharge Characteristics

Voltage	Run Time (Constant Current and Power 25°C 77° F)											
	3 min	5 min	15 min	30 min	45 min	1h	2h	3h	5h	8h	10h	20h
9.6 V	99.4	87.9	50.8	30.8	21.5	17.2	9.27	6.74	4.58	3.01	2.51	1.37
10.2V	89.5	80.3	45.8	28.3	21.0	17.0	9.13	6.67	4.53	3.01	2.51	1.37
10.5V	74.5	70.4	43.2	26.7	20.7	16.7	9.02	6.58	4.53	2.97	2.48	1.34
10.8V	69.5	62.8	40.7	23.0	20.4	16.4	8.74	6.39	4.49	2.97	2.44	1.31

