

JST12-100 (6CNF100)

Characteristics

Nominal Voltage		12V
Nominal Capacity (10 hour rate)		100Ah
Capacity 25°C(77°F)	10 hour rate (10A)	100Ah
	3 hour rate (25A)	75Ah
	1 hour rate (55A)	55Ah
Internal Resistance	Full Charged Battery 25°C(77°F)	≤10m Ω
Cyclic Life	50%(C ₁₀) Depth of discharge	900Times
Float Life	25°C(77°F) Float charge at 13.8V	About 10 Years
Capacity affected by Temperature (10 hour)	40°C (104°F)	102%
	25°C (77°F)	100%
	0°C (32°F)	85%
	-15°C (5°F)	65%
Self-Discharge 25°C(77°F)	Capacity after 3 month storage	90%
	Capacity after 6 month storage	80%
	Capacity after 12 month storage	62%
Charge (Constant Voltage) 25°C (77°F)	Cycle	Initial Charging Current Less than 30A Voltage 14.6-15.0V
	Float	Voltage 13.5-13.8V

Product Image



Packing

Battery (L×W×H)	mm ± 1	329×172×240
	inch	13.0×6.78×9.45
Box (L×W×H)	mm ± 2	352×196×272
	inch	13.9×7.72×10.7
Quantity Per Box		1 PCS
Net weight Per Cell		25Kg ± 150g
Net weight Per Box		25Kg
Gross Weight		25.5Kg

Discharge Curve

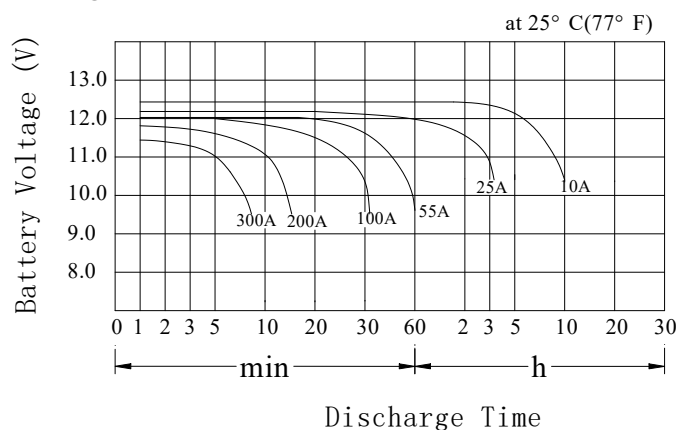

Product Dimensions

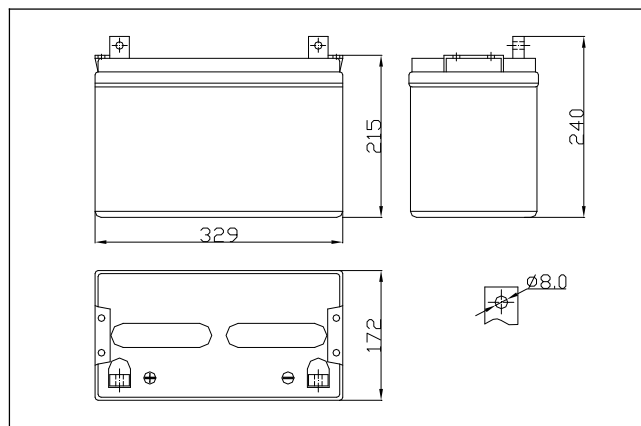

Battery Construction

Component	Positive plate	Negative plate	Container	Safety valve	Terminal	Separator	Electrolyte
Raw Material	Lead dioxide	Lead	ABS	Rubber	Pb	Fiberglass	Sulfuric acid

Discharge Characteristics

Voltage	Run Time (Constant Current and Power 25°C 77° F)										
	3 min	5 min	15 min	30 min	45 min	1h	2h	3h	5h	8h	10h
9.6 V	4370	3800	2150	1380	1030	746	420	315	210	140	124
10.2V	4200	3250	1930	1230	990	736	405	310	208	138	123
10.5V	3850	3080	1820	1120	970	724	390	305	205	136	121
10.8V	3520	2930	1580	1000	940	710	380	290	195	135	120

Discharge Characteristics Curve

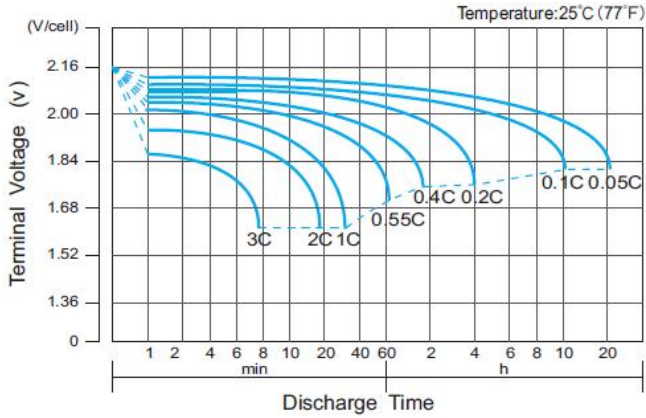

Charging Characteristics

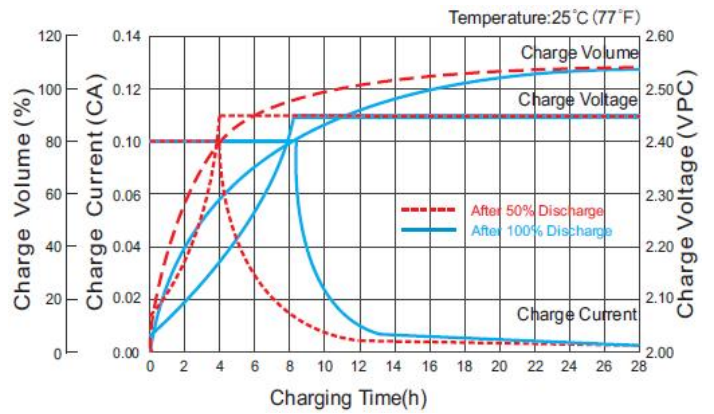

Cycle Life vs. Depth of Discharge (25°C)

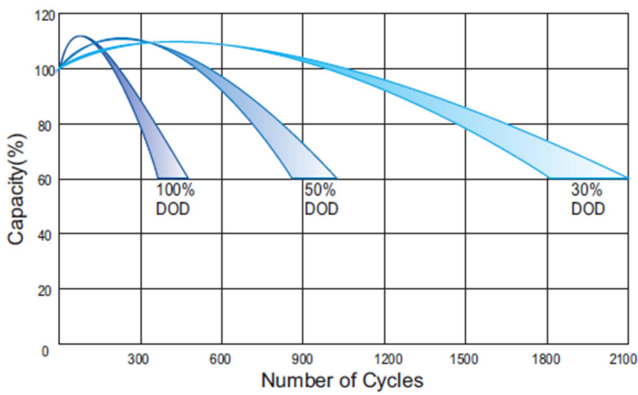

Temperature Effects on Capacity

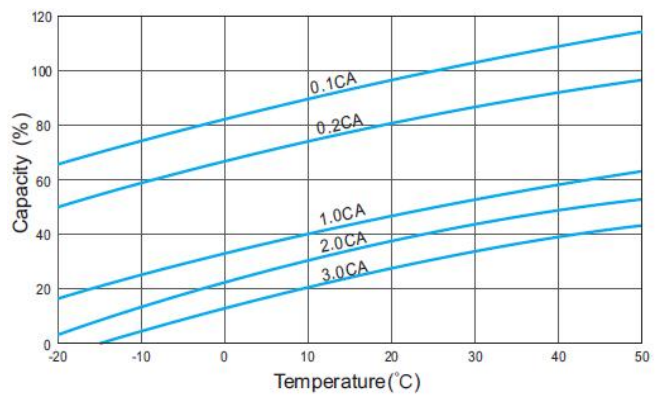

Effect of Temperature on Long Term Life

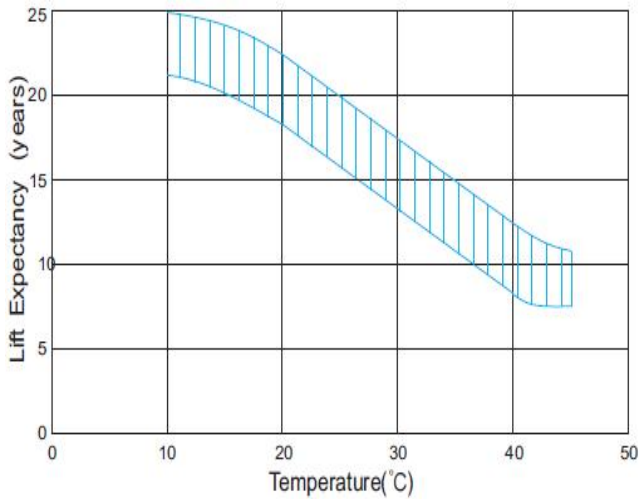

Storage Characteristics

